

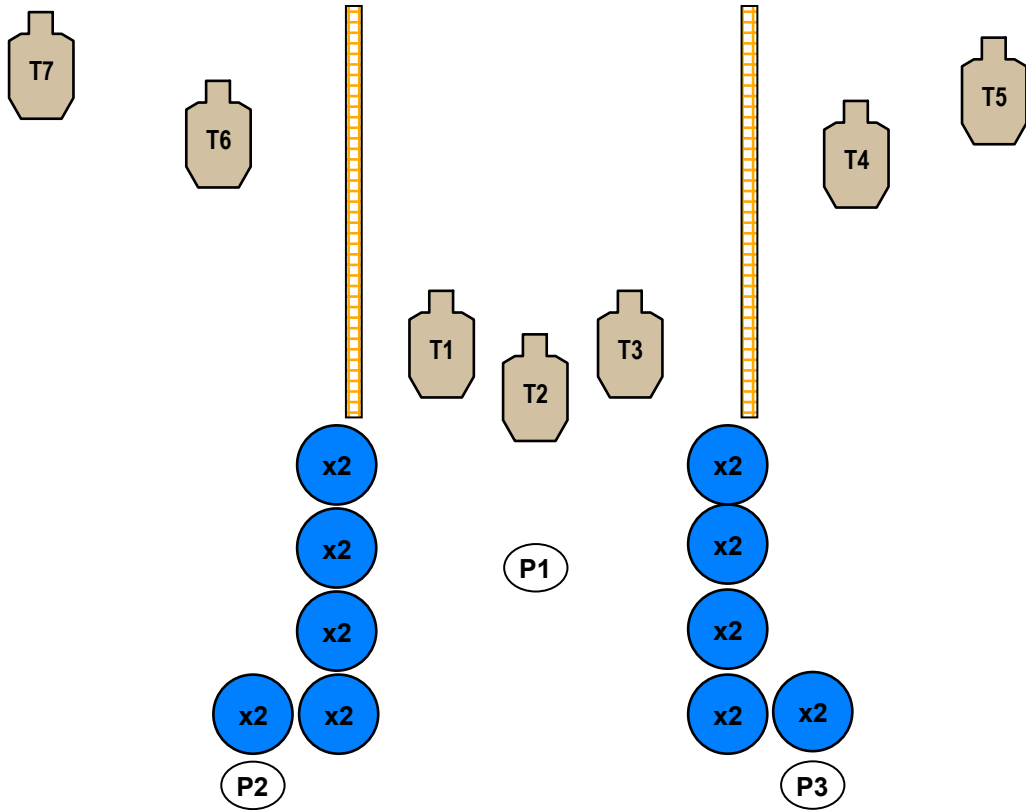

Here we go again



Concealment:	Required	Pistol:	Loaded and holstered	Scoring:	Vickers
Style:	Freestyle	Reload:	IDPA Approved	Min. Rounds:	String 14
Start:	Standing at P1, hands at surrender				
At Signal:	Engage T1 – T3 with 2 shots each in tactical sequence while retreating At P2 Engage T6 –T7 with 2 shots each in tactical priority At P3 Engage T4 – T5 with 2 shots each in tactical priority				
**Notes:	Shooter may go to P2 or P3 first				
Muzzle Safe Points:	180 Degree rule applies				



Stage 2
Bay 2
 Oct. 26, 2013

Squirting Bullets

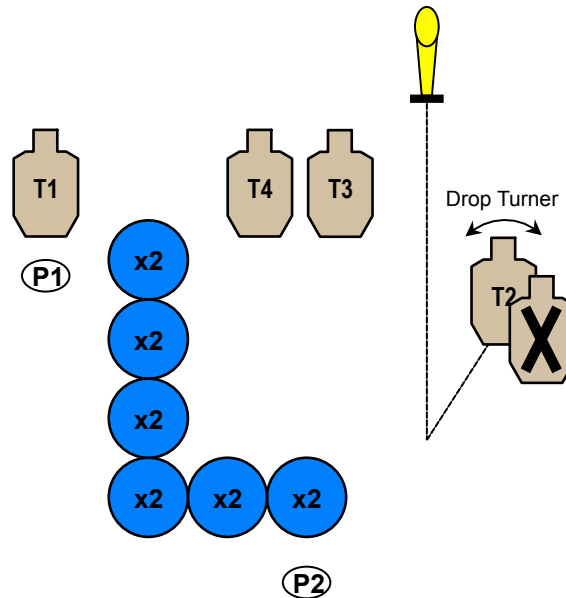

Begin downloaded with (6) rounds!

Concealment:	Yes	Pistol:	Holstered	Scoring:	Vickers
Style:	Freestyle	Reload:	IDPA approved	Min. Rounds:	13
Start:	Standing at P1, wrists above respective shoulders				
At Signal:	Engage T1 with (6) rounds while retreating to P2. From P2, engage popper and T2-T4.				
**Notes:	Competitor may engage static targets T3-T4 while waiting for T2 (Drop Turner) to appear. 180 degree rule applies.				

What happened to the groceries?

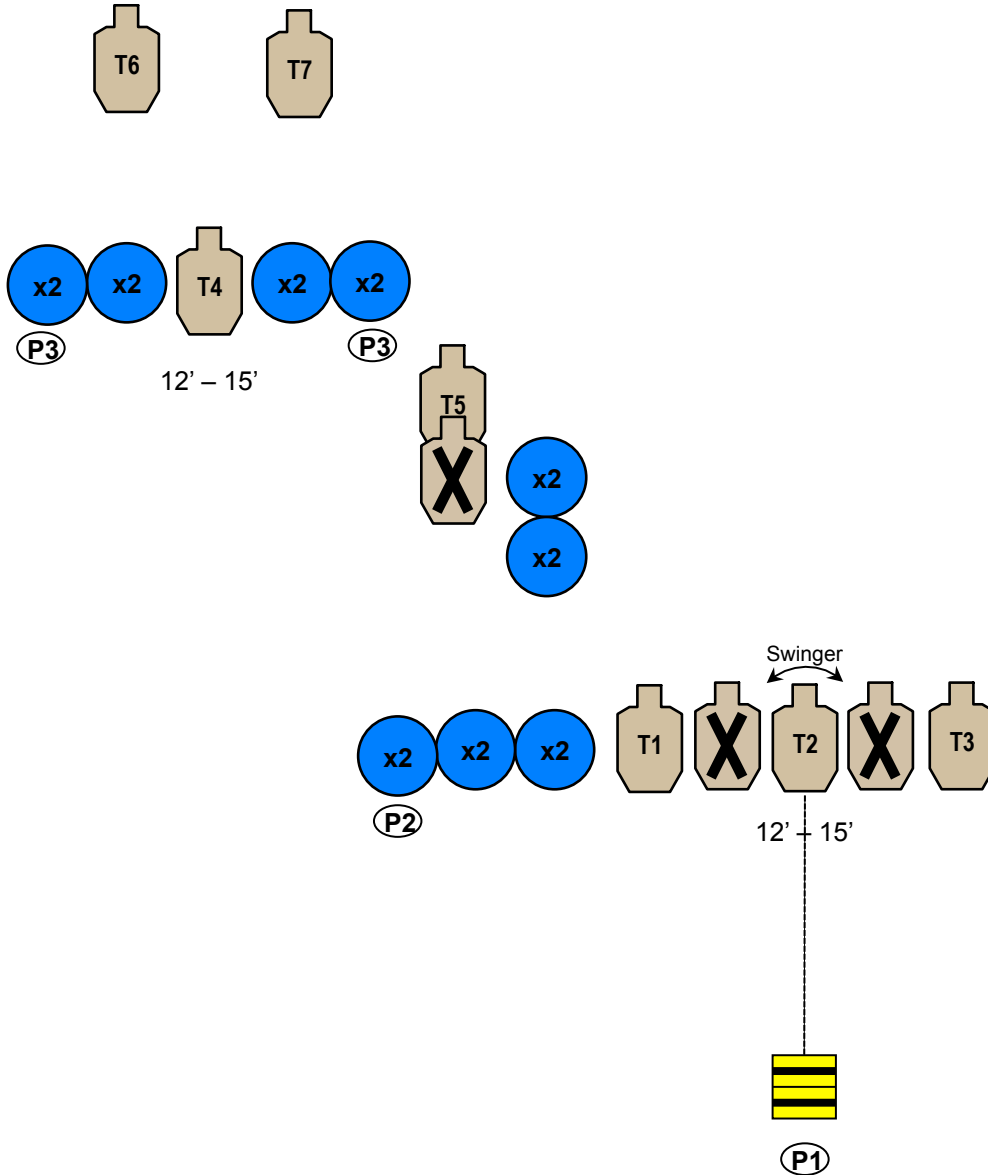

Concealment:	Yes	Pistol:	Holstered	Scoring:	Vickers
Style:	Freestyle	Reload:	IDPA approved	Min. Rounds:	14
Start:	Standing at P1, holding groceries with both hands				
At Signal:	Drop groceries on activator and engage T1-T3 with (2) rounds each in any order, while remaining stationary at P1. Advance to P2 and engage T4-T5 with (2) rounds each. Advance to P3 and engage T6-T7 with (2) rounds each.				
**Notes:	180 degree rule applies				

12 shots too many

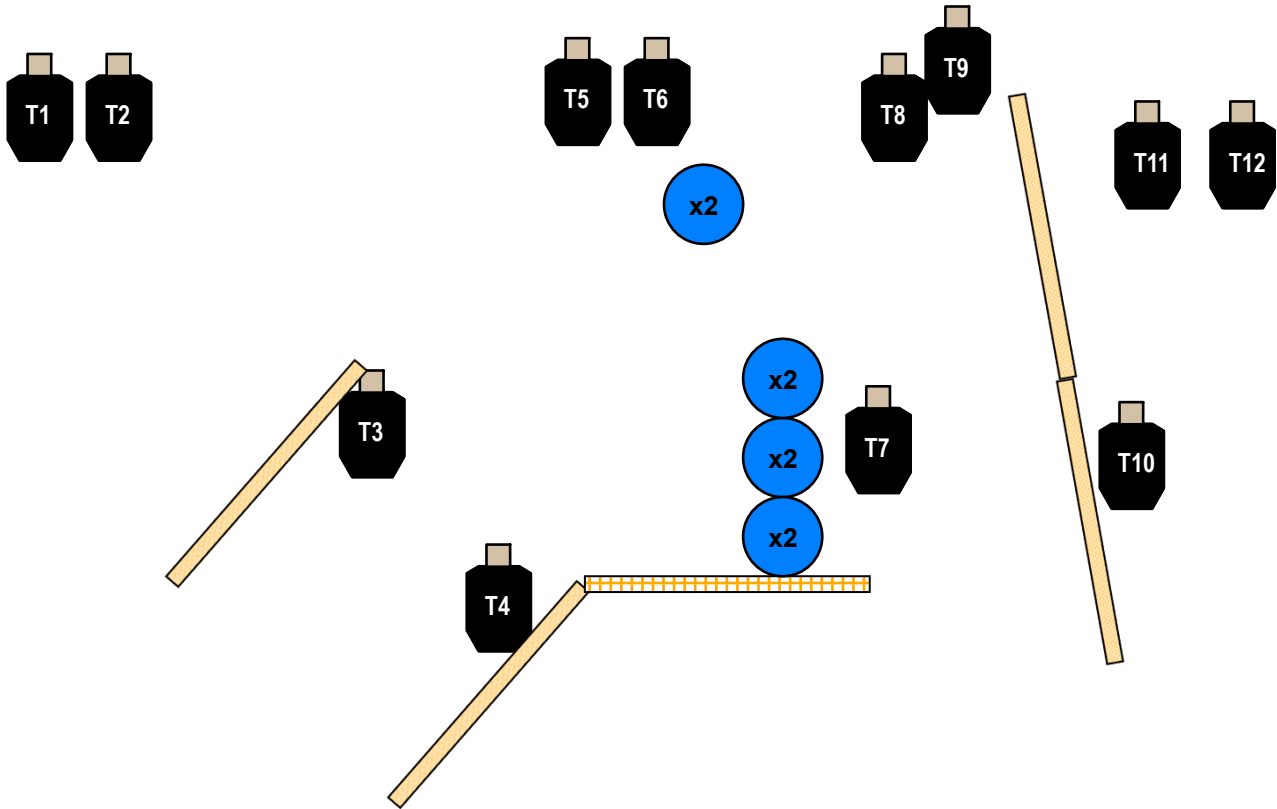

P1

P1



P1

P1

Concealment:	Yes	Pistol:	Holstered	Scoring:	Vickers
Style:	Freestyle	Reload:	IDPA approved	Min. Rounds:	12
Start:	Standing at P1 hands at sides				
At Signal:	Engage T1 – T12 using cover with 1 round each to the head,				
**Notes:	Shooter must be centered on marked P1 positions.. 180 degree rule applies				



Corridor of death

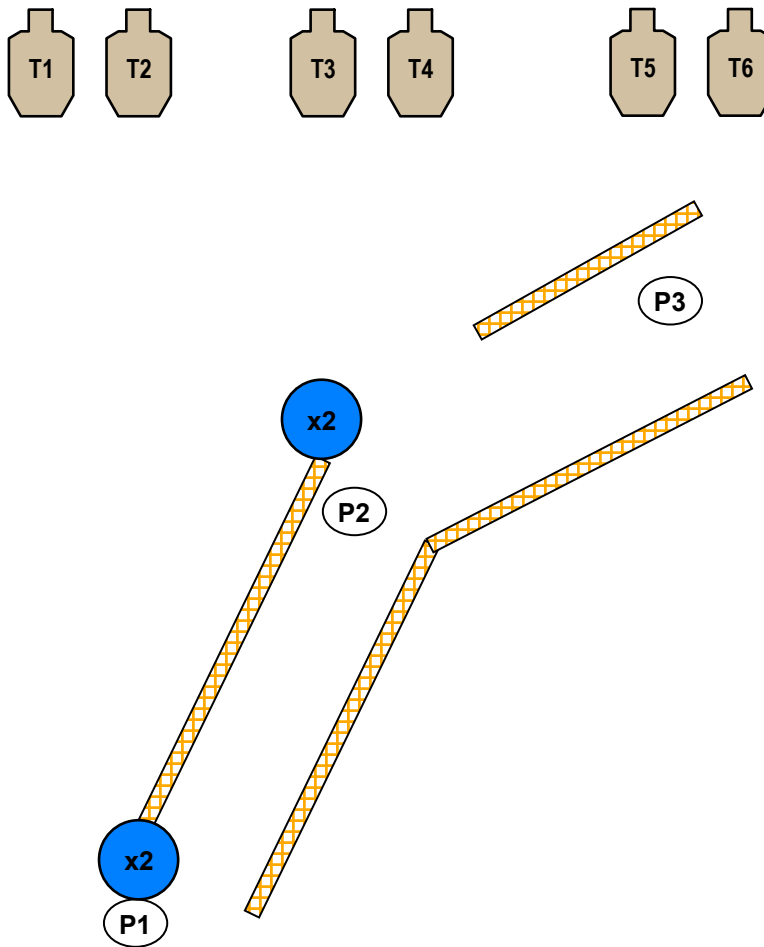

Concealment:	Yes	Pistol:	Loaded and holstered	Scoring:	Vickers
Style:	Freestyle	Reload:	IDPA Approved	Min. Rounds:	12
Start:	Standing at P1 hands at sides				
At Signal:	Engage T1 – T2 with 2 shots each from P1 Move to P2 and Engage T3 – T4 with 2 shots each from P2 Move to P3 and Engage T5 – T6 with 2 shots each from P3				
**Notes:					
Muzzle Safe Points:	180 degree rule applies				